

## Federnde Druckstücke

mit Kugel und Innensechskant • Edelstahl, nichtrostend • Kugel gehärtet

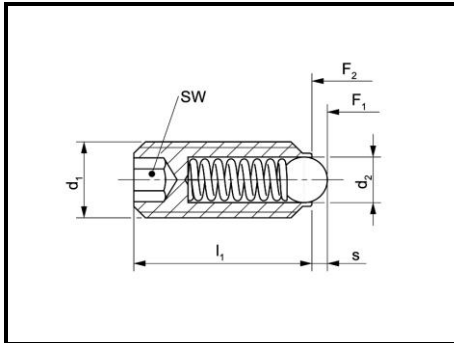

### Ausführungen:

Form KNM: Standard-Federkraft  
(M3 – M24)

Form KNSM: verstärkte Federkraft  
(M4 – M24)

Max. Einsatztemperatur: 250°



### Gewindegewissung und Sonderausführungen auf Anfrage

Artikel-Nr. Form KNM	d <sub>1</sub>	d <sub>2</sub>	l <sub>1</sub>	s	SW	Federkraft		Artikel-Nr. Form KNSM	Federkraft	
						F <sub>1</sub> (N)	F <sub>2</sub> (N)		F <sub>1</sub> (N)	F <sub>2</sub> (N)
02-075 KNM03x9I	M3	1,5	9	0,45	1,5	2,2	3	-	-	-
02-075 KNM04x10I	M4	2,5	10	0,8	2,0	6	12	02-095 KNSM04x10I	10	20
02-075 KNM05x14I	M5	3,0	14	0,9	2,5	7	13	02-095 KNSM05x14I	13	30
02-075 KNM06x15I	M6	3,5	15	1,0	3,0	9	15	02-095 KNSM06x15I	24	40
02-075 KNM08x18I	M8	5,0	18	1,5	4,0	20	35	02-095 KNSM08x18I	40	60
02-075 KNM10x23I	M10	6,0	23	2,0	5,0	25	45	02-095 KNSM10x23I	60	90
02-075 KNM12x26I	M12	8,0	26	2,5	6,0	35	60	02-095 KNSM12x26I	75	115
02-075 KNM16x33I	M16	10,0	33	3,5	8,0	65	110	02-095 KNSM16x33I	115	190
02-075 KNM20x43I	M20	12,0	43	4,5	10,0	80	120	02-095 KNSM20x43I	115	210
02-075 KNM24x48I	M24	15,0	48	5,5	12,0	100	150	02-095 KNSM24x48I	125	240