

Torque Screws

with thrust point to DIN 6332, form S

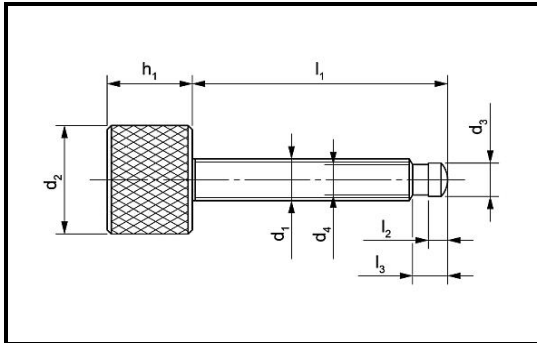

Torque screws are indicated, if a defined, reproducible clamping force is required. Two adjustable, spring-loaded ball pressure elements will unlock, as soon as the final pressure is reached. For pressure-sensitive parts the thrust point can be combined with thrust pads DIN 6311.

Version:

Free cutting steel, black-oxidized, thread case-hardened

Max. clamping force: 250 N

Special versions on request



Product No.	d ₁	l ₁	d ₂	h ₁	d ₃ h11	d ₄	l ₂	l ₃
14-010 M06x40	M6	40	26	20	4,5	4,0	2,5	5,4
14-010 M06x60	M6	60	26	20	4,5	4,0	2,5	5,4
14-010 M08x40	M8	40	26	20	6,0	5,4	3,0	6,8
14-010 M08x60	M8	60	26	20	6,0	5,4	3,0	6,8
14-010 M08x80	M8	80	26	20	6,0	5,4	3,0	6,8
14-010 M10x40	M10	40	26	20	8,0	7,2	4,5	8,2
14-010 M10x60	M10	60	26	20	8,0	7,2	4,5	8,2
14-010 M10x80	M10	80	26	20	8,0	7,2	4,5	8,2
14-010 M12x40	M12	40	26	20	8,0	7,2	4,5	8,2
14-010 M12x60	M12	60	26	20	8,0	7,2	4,5	8,2
14-010 M12x80	M12	80	26	20	8,0	7,2	4,5	8,2
14-010 M12x100	M12	100	26	20	8,0	7,2	4,5	8,2