

Spring Plungers

with hexagon socket • free cutting steel, black-oxidized • bolt hardened

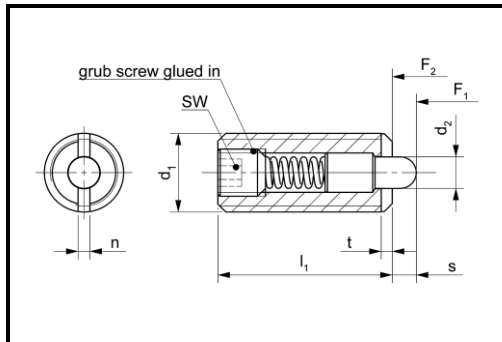

Versions:

Form AM: standard spring load (M3 – M24)

Form ASM: strong spring load (M5 – M24)

Temperature range: up to 150° C



Thread locking and special versions on request

Note: SW = wrench size

Product No. Form AM	d_1	d_2	l_1	n	s	t	SW	Spring load		Product No. Form ASM	Spring load	
								F_1 (N)	F_2 (N)		F_1 (N)	F_2 (N)
02-310 AM03	M3	1,0	12	0,4	1,0	0,5	0,7	1,7	3,5	-	-	-
02-310 AM04	M4	1,5	15	0,6	1,5	0,6	1,3	5	15	-	-	-
02-310 AM05	M5	2,4	18	1,2	2,3	0,8	1,5	7	20	02-320 ASM05	10	40
02-310 AM06	M6	2,7	20	1,3	2,5	0,9	2,0	7	20	02-320 ASM06	18	50
02-310 AM08	M8	3,5	22	1,5	3,0	1,4	2,5	9	35	02-320 ASM08	25	70
02-310 AM10	M10	4,0	22	1,5	3,0	1,4	3,0	9	35	02-320 ASM10	25	70
02-310 AM12	M12	6,0	28	2,7	4,0	2,0	4,0	15	55	02-320 ASM12	45	110
02-310 AM16	M16	7,5	32	3,2	5,0	2,5	5,0	45	100	02-320 ASM16	60	160
02-310 AM20	M20	10,0	40	3,7	7,0	3,0	6,0	60	140	02-320 ASM20	70	200
02-310 AM24	M24	12,0	52	3,7	10,0	3,0	8,0	70	170	02-320 ASM24	75	240